

HEAVY-DUTY WORK LIGHTS

ProSignal™

WLB/WLC



DESCRIPTION

- ▶ The WLB/WLC™ Work lights are part of our Heavy-Duty line. Assembled in a die-cast aluminum housing, they are completely weatherproof and resistant to vibration.
- ▶ They been tested by our customers in the worst conditions and always responded perfectly.

FEATURES

- ▶ Multi-voltage input: 11 to 70Vdc
- ▶ 1900 lumens
- ▶ 6 High intensity LED modules
- ▶ LEDs rated to 100 000 hours of operation
- ▶ Heavy-Duty powder coated die cast aluminium
- ▶ Reverse polarity protection
- ▶ EMC & IP67 Compliance
- ▶ Flood beam



ELECTRICAL SPECIFICATIONS

Operating Voltage:	11 to 70Vdc
Maximum Current:	2A at 12.8Vdc / 0.9A at 25.6Vdc
Maximum Power:	27 Watts
Fuse Recommended:	5A

LIGHT PATTERN

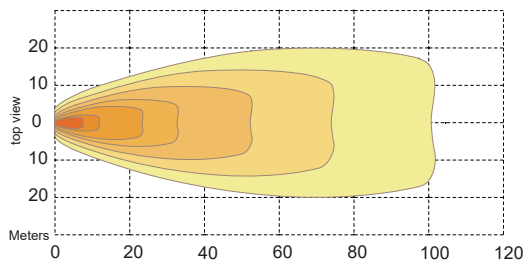

DIMENSIONS

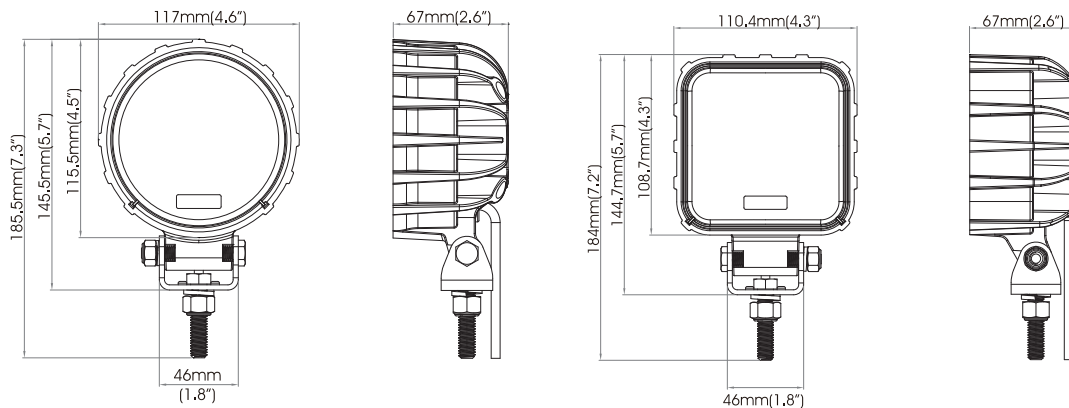

PRODUCT NUMBERS

Number	Description
63101Z	PROSIGNAL - WORK LIGHT - WLB 6 LED ROUND 1900 lm - FLOOD
63131Z	PROSIGNAL - WORK LIGHT - WLC 6 LED SQUARE 1900 lm - FLOOD