



# ST3



## DESCRIPTION

- ▶ Fully waterproof, the super thin ST3™ module can be installed in any location. It is ideal for installations requiring the utmost discretion.
- ▶ Its design meets SAE J845 Class I standards.

## FEATURES

- ▶ Multi-voltage input: 12 to 24Vdc
- ▶ 12 flash patterns
- ▶ High intensity LED modules (3 LED modules of 1 Watt)
- ▶ LEDs rated to 100 000 hours of operation
- ▶ Non-volatile memory recalls last flash pattern used at power up
- ▶ Weatherproof and vibration resistant design for internal or external use
- ▶ White bezel and Chrome bezel are available to match the vehicle color
- ▶ Reverse polarity protection
- ▶ Multiple units can be synchronized
- ▶ Color available:   



## ELECTRICAL SPECIFICATIONS

<b>Operating Voltage:</b>	12 to 24Vdc
<b>Maximum Current:</b>	0.4A at 12Vdc / 0.22A at 24Vdc
<b>Average Power:</b>	2.7 Watts at 12Vdc [varies with flash pattern]
<b>Maximum Power:</b>	5.5 Watts
<b>Fuse Recommended:</b>	1A

## BEZEL AVAILABLE



## DIMENSIONS

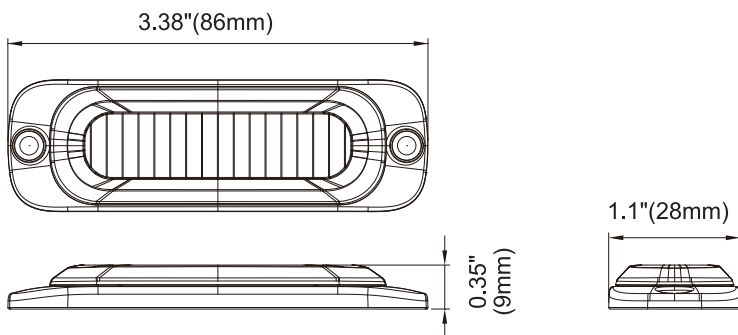

## PRODUCT NUMBERS

Number	Description
21403Z	PROSIGNAL - ST3 - 3 LED SURFACE/MT - AMBER
21402Z	PROSIGNAL - ST3 - 3 LED SURFACE/MT - RED
21405Z	PROSIGNAL - ST3 - 3 LED SURFACE/MT - BLUE
21430Z	PROSIGNAL - ST3 - BEZEL - CHROME
21431Z	PROSIGNAL - ST3 - BEZEL - WHITE