

SILVER BLADE



DESCRIPTION

- ▶ The Silver Blade™ checks all the boxes for the ideal strobe LED Lightbar. Low profile (1.6”), ultra-robust, and an advanced waterproof design.
- ▶ Its superior 360° illumination exceeds SAE J845 Class 1 and NFPA 1901 standards.

FEATURES

- ▶ Voltage input: 12Vdc
- ▶ 30 selectable flash patterns
- ▶ Integrated flash patterns adapted for night operations (Pulsing)
- ▶ External CAN module included which reduces the number of wires and facilitates installation
- ▶ Software available for easy configurations of different scenarios
- ▶ LEDs rated to 100 000 hours of operation
- ▶ Available with dual and tri-color LED feature and scene lights
- ▶ Includes traffic arrow option
- ▶ High-grade weatherproof and vibration resistant design
- ▶ Reverse polarity protection
- ▶ Color available: A series of seven color swatches representing different lightbar configurations: yellow, red, blue, red/blue, blue/red, yellow/red, and blue/yellow.

ELECTRICAL SPECIFICATIONS

Operating Voltage:	12Vdc
Maximum Current:	5.3A at 12.8Vdc
Maximum Power:	67.6 Watts

*Consumption in Steady-On mode.

DIMENSIONS

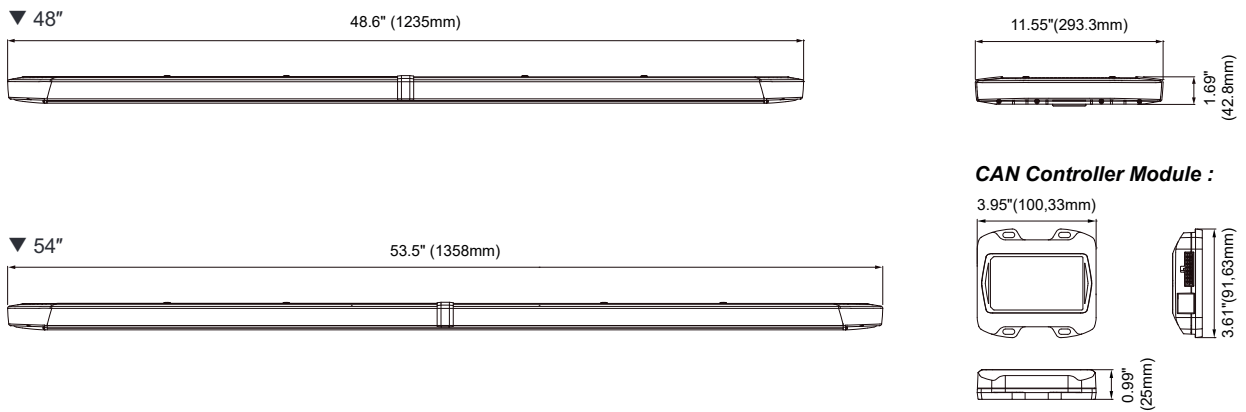

PRODUCT NUMBERS

Number	Description
39607Z	PROSIGNAL - SILVERBLADE 49" AMBRE - TD+AL
39616Z	PROSIGNAL - SILVERBLADE 49" RED/DUAL WHITE /REAR AMBER - SCENE LIGHTS
39617Z	PROSIGNAL - SILVERBLADE 49" RED/BLUE WHITE /REAR AMBER - SCENE LIGHTS
39716Z	PROSIGNAL - SILVERBLADE 54" RED/DUAL WHITE /REAR AMBER - SCENE LIGHTS