

# LEGION FIT



## DESCRIPTION

- ▶ Fully waterproof & vibration resistant, the LEGION FIT™ lightbar is available in several lengths. It's the most economical in its class.
- ▶ Its design meets SAE J845 Class I standards.

## FEATURES

- ▶ Multi-voltage input: 12 to 24Vdc
- ▶ 26 selectable flash patterns
- ▶ LEDs rated to 100 000 hours of operation
- ▶ Non-volatile memory recalls last flash pattern used at power up
- ▶ Low power function for night time use
- ▶ Weatherproof and vibration resistant design for internal or external use
- ▶ Reverse polarity protection
- ▶ Color available: 

## ELECTRICAL SPECIFICATIONS

<b>Operating Voltage:</b>	12 to 24Vdc
<b>Maximum Current:</b>	8.1A at 12.8Vdc / 4.4A at 25.6Vdc
<b>Average Current:</b>	5A at 12.8Vdc / 3A at 25.6Vdc
<b>Fuse Recommend:</b>	12V=15A / 24V=7.5A

\*Consumption in Steady-On mode.

## DIMENSIONS

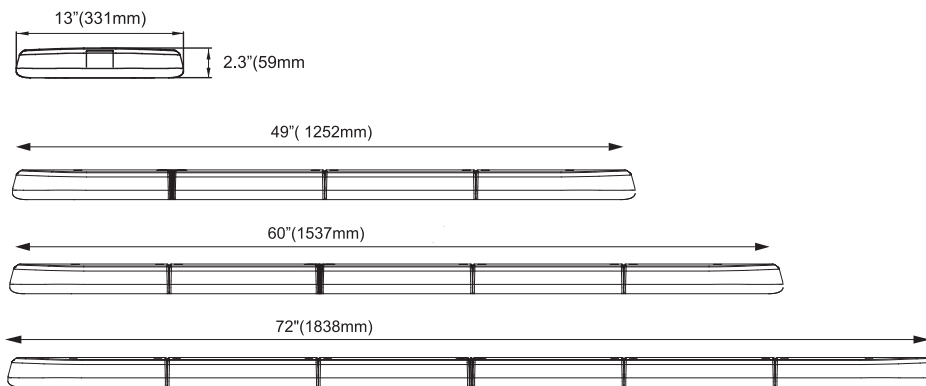

## PRODUCT NUMBERS

Number	Description
<b>34601Z</b>	PROSIGNAL - LEGION FIT 49" - 3 LED MODULE - AMBER
<b>34901Z</b>	PROSIGNAL - LEGION FIT 60" - 3 LED MODULE - AMBER **NO INSTALLATION FEET**
<b>35001Z</b>	PROSIGNAL - LEGION FIT 72" - 3 LED MODULE - AMBER
<b>LB-0435</b>	UNIVERSAL "U" STEEL BRACKETS 1/8" - BLACK (TWO UNITS)