

BISON



DESCRIPTION

- ▶ Fully waterproof, the BISON™ is the perfect choice for those who want to save time and money. This kit includes everything you need for a quick installation: an 8-button keypad, installation brackets, and a 15' plug & play harness.
- ▶ You can also order a longer extension cable of 35' or 55' if needed.
- ▶ This product meets SAE J595 Class I standards.

FEATURES

- ▶ Multi-voltage input: 12 to 24Vdc
- ▶ 32 LEDs offering high intensity warning visibility
- ▶ This unique design allows exceptional visibility even under a blazing sun
- ▶ 4 Traffic arrow flash patterns
- ▶ 6 Warning flash patterns
- ▶ 4 Cruise mode flash patterns
- ▶ Weatherproof and vibration resistant design for internal or external use
- ▶ Versatile installation with L-brackets.
- ▶ Reverse polarity protection
- ▶ Color available: 

ELECTRICAL SPECIFICATIONS

Operating Voltage:	12Vdc
Maximum Current:	2.48A at 12Vdc / 1.24A at 24Vdc
Maximum Power:	29.8W
Fuse Recommended:	5A

DIMENSIONS

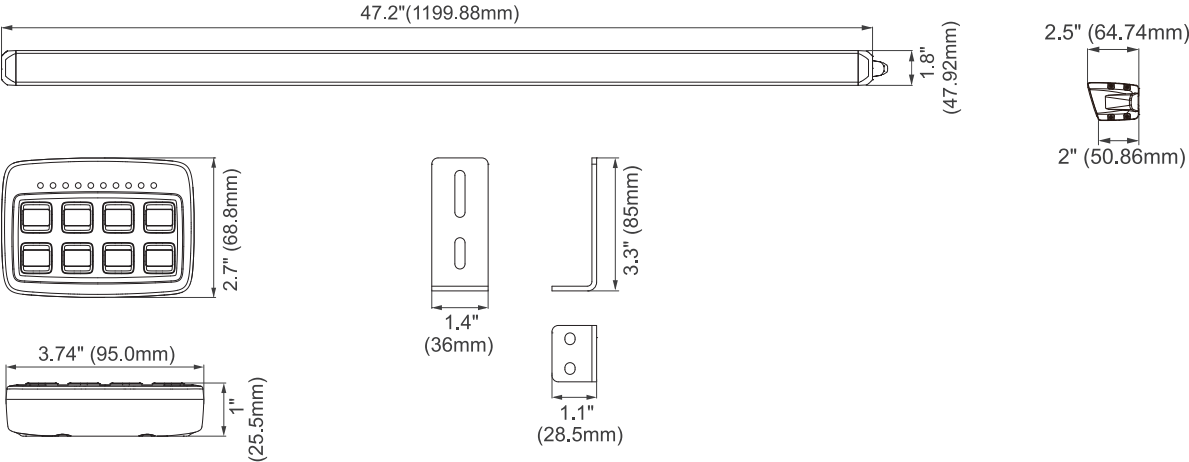

MOUNTING BRACKETS



Support "L" (2X)

KEYBOARD PANEL



PANNEAU DE CONTRÔLE
8 BOUTONS

PRODUCT NUMBERS

Number	Description
33813Z	PROSIGNAL - 48" ARROW STICK + CONTROL PANNEL, (2x) L-BRACKETS & 15FT CABLE