

B17



DESCRIPTION

- ▶ The B17 is a mid-size beacon that fit on all type on installations.
- ▶ Its design offer 360° output that meets SAE J845 Class I standards.

FEATURES

- ▶ Multi-voltage input: 12 to 24Vdc
- ▶ 15 selectable flash patterns
- ▶ High intensity LED modules (8 LED modules of 1 Watt)
- ▶ LEDs rated to 100 000 hours of operation
- ▶ Non-volatile memory recalls last flash pattern used at power up
- ▶ Weatherproof and vibration resistant design for internal or external use
- ▶ Available in permanent or magnetic mount
- ▶ Offers various mounting brackets: Shelf Mount & Mirror Mount
- ▶ Reverse polarity protection
- ▶ Multiple units can be synchronized
- ▶ Color available: 

ELECTRICAL SPECIFICATIONS

Operating Voltage:	12 to 24Vdc
Maximum Current:	1.1A at 12Vdc / 0.6A at 24Vdc
Average Power:	16 Watts (varies with pattern)
Maximum Power:	32 Watts
Fuse Recommended:	4A

OPTIONAL MOUNTING BRACKETS

Shelf Mount

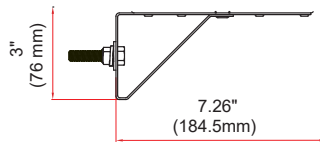

Mirror Mount

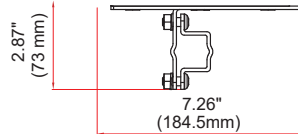

ACCESSORIES



77203Z-GUARD

DIMENSIONS

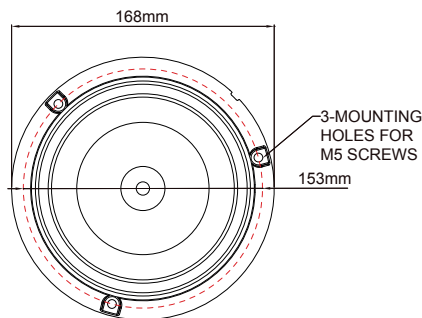
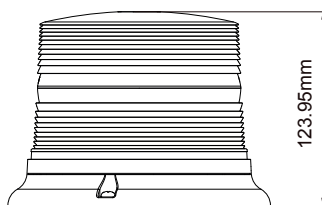

PRODUCT NUMBERS

Number	Description
77203Z	PROSIGNAL - BEACON B17 - 8-LED PERMANENT - AMBER
77213Z	PROSIGNAL - BEACON B17 - 8-LED MAGNETIC - AMBER
77xxxZ-SHELF	PROSIGNAL - BEACON B15/B17/B19 MOUNTING BRACKET - SHELF
77xxxZ-MIRROR	PROSIGNAL - BEACON B15/B17/B19 MOUNTING BRACKET - MIRROR
77203Z-GUARD	PROSIGNAL - BEACON B17 BRANCH GUARD
78003Z	PUMP VACUUM SUCTION CUP + PLATE FOR BEACON