

B16



DESCRIPTION

- ▶ Featuring a dust cover lens, the B16™ Beacon is ideal for installation on smaller vehicles.
- ▶ It is very easy to maintain and its small size is perfect for vehicles with limited space. The B16™ Meets SAE J845 Class I standards.

FEATURES

- ▶ Multi-voltage input: 12 to 24Vdc
- ▶ 11 selectable flash patterns
- ▶ High intensity LED modules (8 LED modules of 3 Watts)
- ▶ LEDs rated to 100 000 hours of operation
- ▶ Non-volatile memory recalls last flash pattern used at power up
- ▶ Weatherproof and vibration resistant design for internal or external use
- ▶ Available in permanent or magnetic mount
- ▶ Reverse polarity protection
- ▶ Multiple units can be synchronized
- ▶ Color available: 

ELECTRICAL SPECIFICATIONS

Operating Voltage:	12 to 24Vdc
Maximum Current:	2.4A at 12Vdc / 1.3A at 24Vdc
Average Power:	15 Watts (varies with pattern)
Maximum Power:	30 Watts
Fuse Recommended:	5A

CONNECTING OPTIONS



ACCESSORIES



77103Z-GUARD

DIMENSIONS

3-Bolt Mount

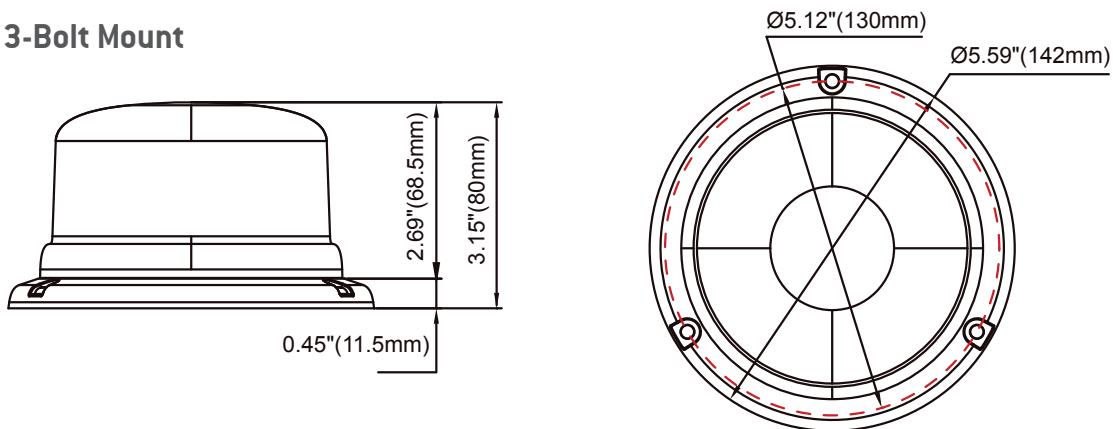

PRODUCT NUMBERS

Number	Description
77103Z	PROSIGNAL - BEACON-B16 - 8 LED PERMANENT - AMBER
77113Z	PROSIGNAL - BEACON B16 - 8-LED MAGNETIC - AMBER
77103Z-GUARD	PROSIGNAL - BEACON B16 BRANCH GUARD
78003Z	PUMP VACUUM SUCTION CUP + PLATE FOR BEACON