

B12



DESCRIPTION

- ▶ The B12™ offers a more sustainable alternative and a more powerful brightness than the older generation with a xenon tube.
- ▶ This beacon is ideal for workers who need to access a construction site or those offering snow removal or landscaping services. The B12™ Meets SAE J845 Class II standards.

FEATURES

- ▶ Multi-voltage input: 11 to 110Vdc
- ▶ 5 selectable flash patterns
- ▶ LED modules (3 LED modules of 1 Watt)
- ▶ LEDs rated to 100 000 hours of operation
- ▶ Non-volatile memory recalls last flash pattern used at power up
- ▶ Weatherproof and vibration resistant design for internal or external use
- ▶ Available in permanent or magnetic mount
- ▶ Reverse polarity protection
- ▶ Multiple units can be synchronized
- ▶ Color available: 

ELECTRICAL SPECIFICATIONS

Operating Voltage:	11 to 110Vdc
Average Current:	0.2A at 12Vdc / 0.7A at 110Vdc
Average Power:	2.56 Watts at 12.8Vdc / 7.7 Watts at 110Vdc
Fuse Recommended:	1A

CONNECTING OPTIONS

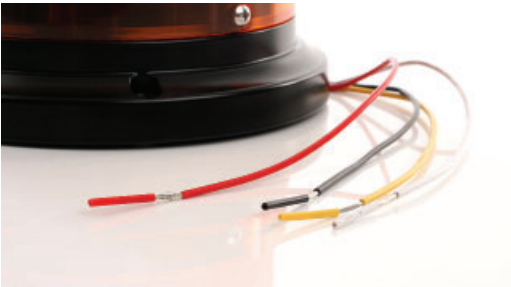

DIMENSIONS

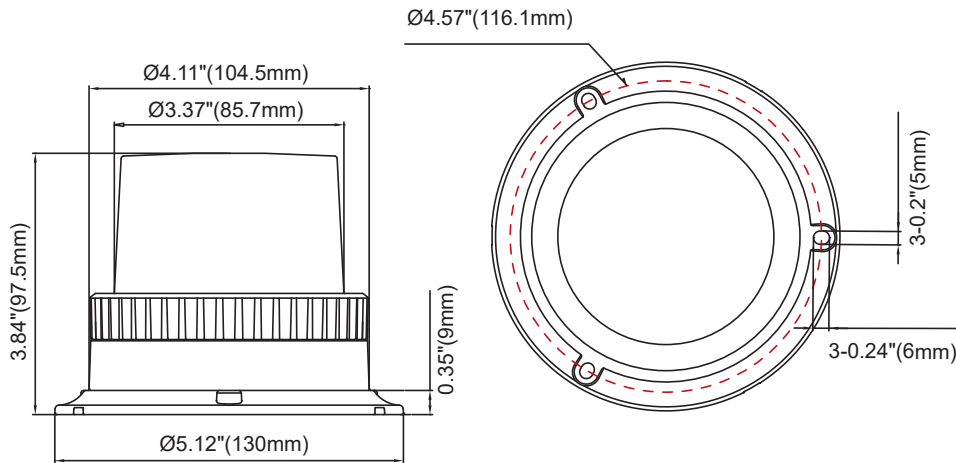

PRODUCT NUMBERS

Number	Description
77703Z	PROSIGNAL - BEACON B12 - 3-DEL PERMANENT/MT 11-110V - AMBER
77713Z	PROSIGNAL - BEACON B12 - 3-DEL MAGNETIC/MT 11-110V - AMBER
777x3Z-LENS	PROSIGNAL - BEACON B12 - LENS - AMBER