

B11



DESCRIPTION

- ▶ The B11™ offers a more sustainable alternative and a more powerful brightness than the older generation with a xenon tube.
- ▶ This beacon meets SAE J845 Class II standards. Its perfect for installation on forklift or elevating work platform.

FEATURES

- ▶ Multi-voltage input: 11 to 110Vdc
- ▶ 1 flash pattern
- ▶ LED modules (3 LED modules of 1 Watt)
- ▶ LEDs rated to 100 000 hours of operation
- ▶ Non-volatile memory recalls last flash pattern used at power up
- ▶ Weatherproof and vibration resistant design for internal or external use
- ▶ Available in permanent or magnetic mount
- ▶ Reverse polarity protection
- ▶ Color available: 



ELECTRICAL SPECIFICATIONS

| | |
|---------------------------|---|
| Operating Voltage: | 11 to 110Vdc |
| Average Current: | 0.2A at 12.8Vdc / 0.07A at 110Vdc |
| Average Power: | 2.56 Watts at 12.8Vdc / 7.7 Watts at 110Vdc |
| Fuse Recommended: | 1A |

CONNECTING OPTIONS

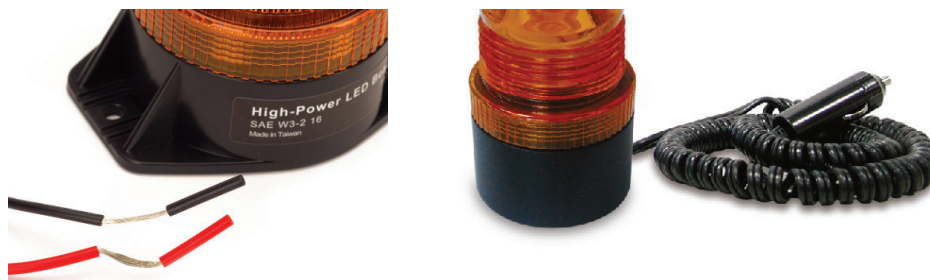

DIMENSIONS

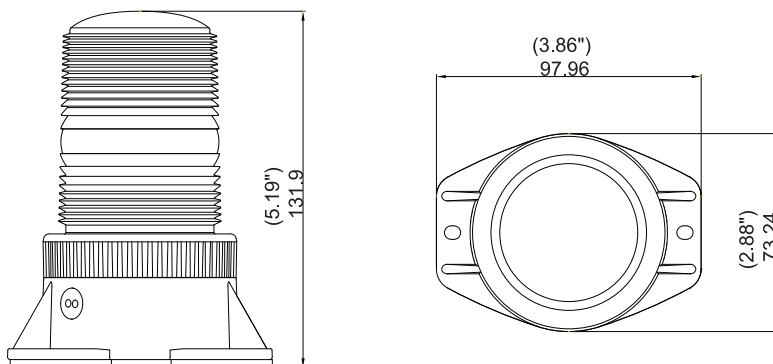

PRODUCT NUMBERS

| Number | Description |
|--------------------|---|
| 77803Z | PROSIGNAL - BEACON B11 - 3-DEL PERMANENT/MT 11-110V - AMBER |
| 77813Z | PROSIGNAL - BEACON B11 - 3-DEL MAGNETIC/MT 11-110V - AMBER |
| 778x3Z-LENS | PROSIGNAL - BEACON B11 - LENS - AMBER |