

64171Z



DESCRIPTION

- ▶ Fully waterproof and vibration resistant, the 64171Z™ work light is perfect for machinery operator who wants to upgrade their halogen PAR 36 to LED. It is also very popular for Truck Drivers who wants to fit a work light in their trailer as a backup light.
- ▶ Ideal for applications such as: Agriculture, Excavation & Road Transport.

FEATURES

- ▶ Flood Beam
- ▶ Multi-voltage input: 12 to 24Vdc
- ▶ 1440 lumens
- ▶ 6 LED of 3 Watts
- ▶ CREE LED
- ▶ LEDs rated to 30 000 hours of operation
- ▶ Made of aluminum alloy & polycarbonate lens.
- ▶ Color Temperature: 6000K
- ▶ Water & vibration resistant
- ▶ Certificates: IP67

ELECTRICAL SPECIFICATIONS

Operating Voltage:	12 to 24Vdc
Current Draw:	1.5A at 12Vdc / 0.75A at 24Vdc
Maximum Power:	18 Watts
Fuse Recommended:	2A

DIMENSIONS

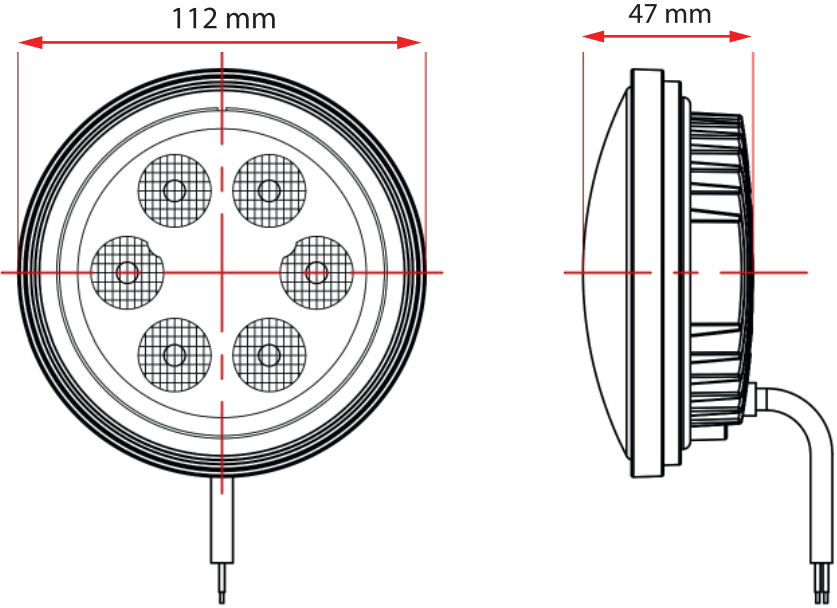

PRODUCT NUMBERS

Number	Description
64171Z	PROSIGNAL - BUILT-IN ROUND LED WORKLIGHT 18W - 1440Lm – 4.5”