

HEAVY-DUTY WORK LIGHTS

ProSignal™

64061Z



DESCRIPTION

- ▶ The 64061Z™ work light is part of our Heavy-Duty line. It is for customer who really need a strong scene light to work with precision. Assembled in a die-cast aluminum housing, these work lights are completely weatherproof and resistant to vibration. Its mounting bracket is adjustable and made of 304 stainless steel which have an excellent corrosion resistance.
- ▶ Ideal for applications such as: Agriculture, Excavation, Industrial and Forestry Work.

FEATURES

- ▶ Multi-voltage input: 12 to 24Vdc
- ▶ Up to 21 000 Lm
- ▶ 36 LED of 5 Watts (Osram LED)
- ▶ Color Temperature: 6000K
- ▶ Water & vibration resistant
- ▶ Temperature control system for longer lifetime
- ▶ Certificates: CE, RoHS, IP67, IP69K, ECE, R10
- ▶ This is the Flood beam version

ELECTRICAL SPECIFICATIONS

Operating Voltage:	12 to 24Vdc
Current Draw:	10A at 12Vdc / 5A at 24Vdc
Maximum Power:	180 Watts
Fuse Recommended:	12A

LIGHT PATTERN

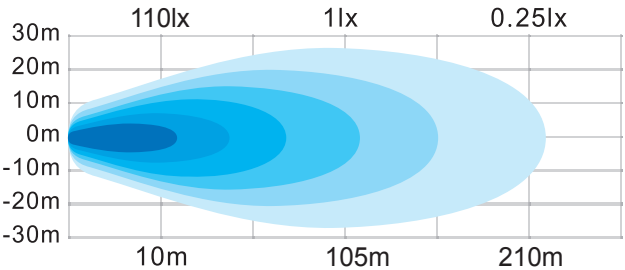

DIMENSIONS

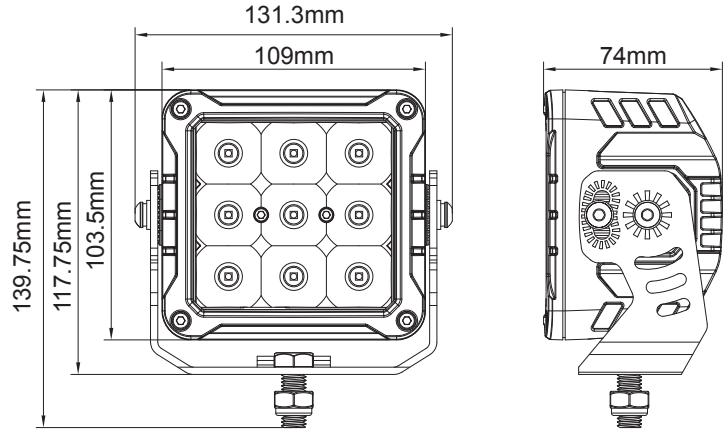

PRODUCT NUMBERS

Number	Description
64061Z	PROSIGNAL - WORK LIGHT 21 000 lm SQUARE - FLOOD