

DOMES LIGHTS

60201Z / 60202Z 60203Z

ProSignal™



6000K

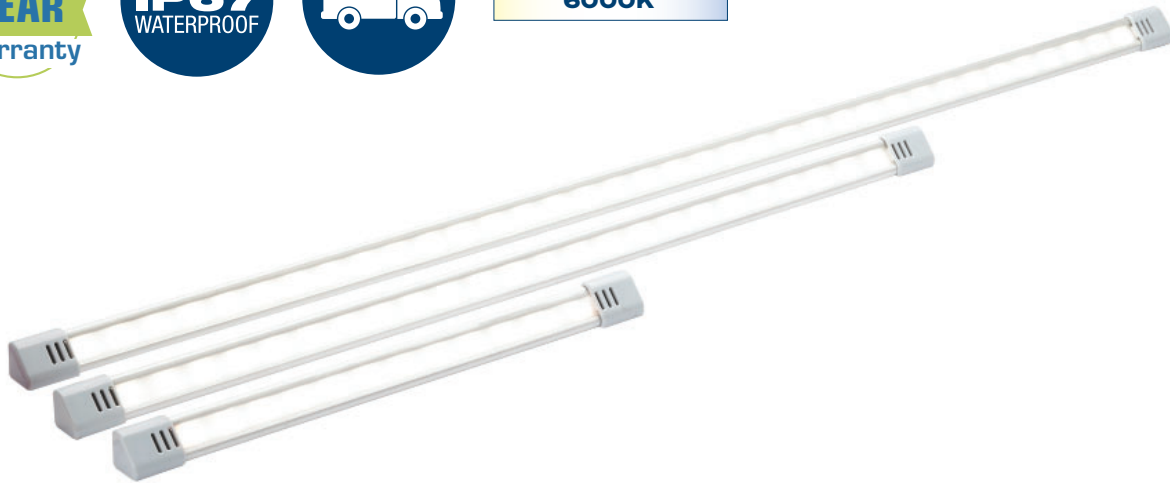

DESCRIPTION

- ▶ The 60201Z/02Z/03Z™ LED strip dome lights are part of our professional grade products. Its 45° angle makes it perfect to install in a corner. It is ideal for customers who need to increase the intensity of lighting in their workspace.
- ▶ These dome lights are waterproof but more efficient in interior uses.

FEATURES

- ▶ Multi-voltage input: 12V to 24Vdc
- ▶ 360 lumens - 12 LED (60201Z)
- ▶ 720 lumens - 24 LED (60202Z)
- ▶ 1080 lumens - 36 LED (60203Z)
- ▶ Surface Mount
- ▶ Hidden mounting holes
- ▶ Heavy-duty design
- ▶ Excellent aluminum heat sink
- ▶ Polycarbonate frosted lens
- ▶ Color Temperature: 6000K
- ▶ Certificates: R10, IP67

ELECTRICAL SPECIFICATIONS

Operating Voltage:	12 to 24Vdc
Current Draw:	0.24A at 12Vdc / 0.12A at 24Vdc (60201Z) 0.46A at 12Vdc / 0.23A at 24Vdc (60202Z) 0.69A at 12Vdc / 0.34A at 24Vdc (60203Z)

DIMENSIONS

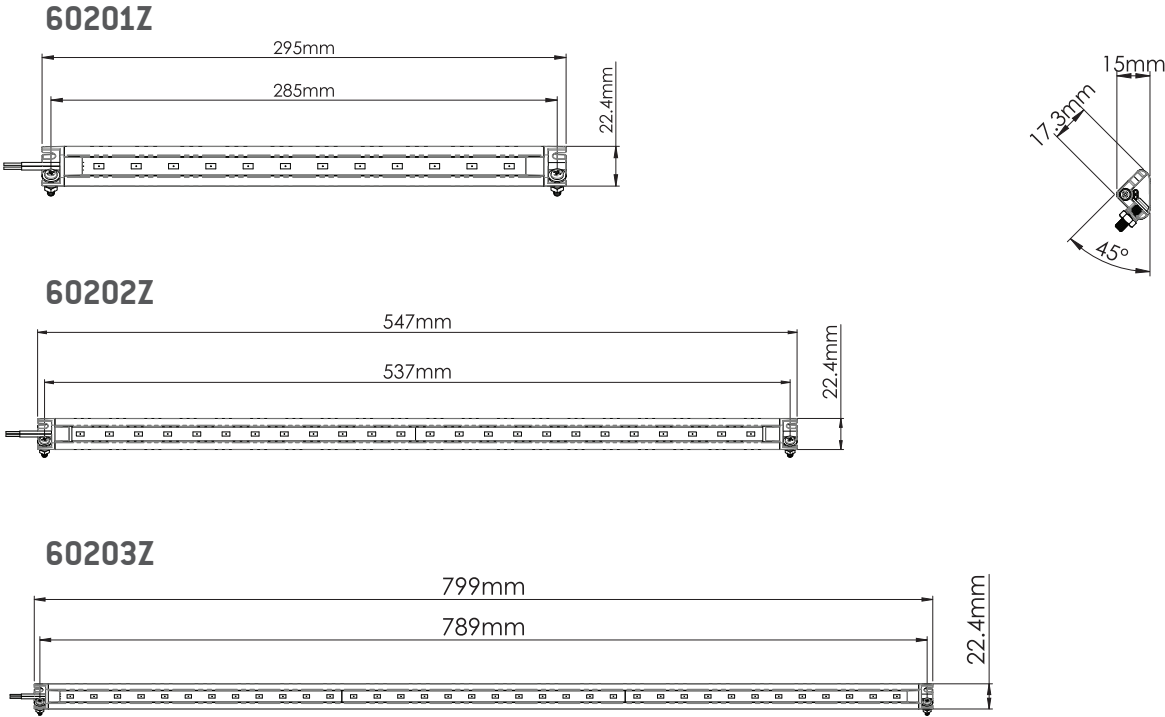

PRODUCT NUMBERS

Number	Description
60201Z	PROSIGNAL - STRIP DOME LIGHT 360 lm - 45° FROSTED LENS - 12"
60202Z	PROSIGNAL - STRIP DOME LIGHT 720 lm - 45° FROSTED LENS - 21"
60203Z	PROSIGNAL - STRIP DOME LIGHT 1080 lm - 45° FROSTED LENS - 31"