

## DRIVING LIGHTS

# LED-HL-5X7-SP

**ProSignal™**



Position lights & turn signals built in

## DESCRIPTION

- ▶ The LED-HL-5X7-SP™ heated headlight is ideal for snow-plow truck owners wanting to improve their night driving by remaining legal. Assembled in a die-cast aluminum housing, these headlights are completely weatherproof and resistant to vibration. Their beam pattern is SAE DOT approved for the road. If the temperature goes below 0° Celsius the lens will start to heat up to melt the snow.

## FEATURES

- ▶ High & Low Beam Version
- ▶ Multi-voltage input: 12 to 24Vdc
- ▶ 1008 lumens (Low Beam) / 1380 lumens (High Beam)
- ▶ 2 Osram LED of 15 Watts (Low Beam)
- ▶ 3 CREE LED of 10 Watts (High Beam)
- ▶ Position lights & turn signals built in
- ▶ Self heating lens for snow melting
- ▶ Die-cast aluminum housing & polycarbonate lens
- ▶ Allows two ways of mounting: bottom and rear
- ▶ Color Temperature: 6000K
- ▶ Water & vibration resistant
- ▶ Certificates: CE, RoHS, IP67, IP69K, ECE, R10, DOT



## ELECTRICAL SPECIFICATIONS

<b>Operating Voltage:</b>	12 to 24Vdc
<b>Current Draw:</b>	1.48A to 12Vdc / 0.74A to 24Vdc (Low Beam) 1.76A to 12Vdc / 0.88A to 24Vdc (High Beam)
<b>Maximum Power:</b>	60 Watts

## DIMENSIONS

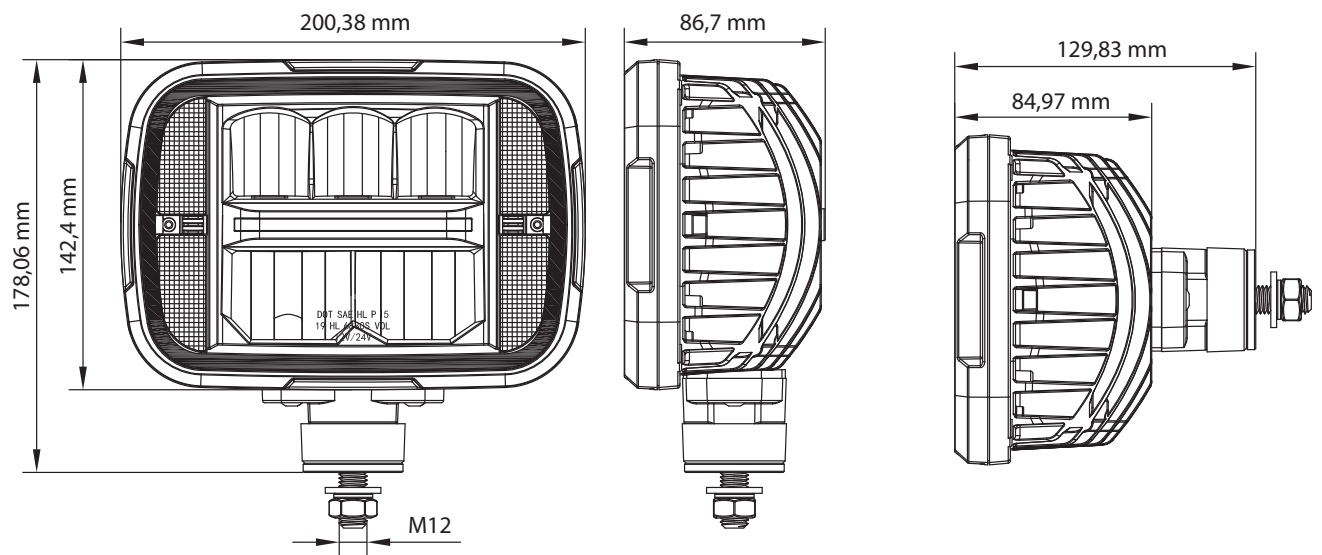

## PRODUCT NUMBERS

Number	Description
LED-HL-5X7-SP	PROSIGNAL - PAIR OF SNOW-PLOW LED HEADLIGHTS (HI & LO) DOT - HEATED