

## PERIMETER LIGHTING

# HAL09

**ProSignal™**



### DESCRIPTION

- ▶ The HAL09™ have been designed to be installed in vehicle lamp housings. This 2-head kit is way more efficient and reliable than the old models of strobe lights.
- ▶ They can be used as well for surface mounting using the black bezels include in the box. White or chrome bezels are also available to order to match the vehicle color.
- ▶ Its design meets SAE J845 Class I standards.

### FEATURES

- ▶ Multi-voltage input: 12 to 24Vdc
- ▶ 19 flash patterns
- ▶ High intensity LED modules (9 LED modules of 1 Watt per head)
- ▶ LEDs rated to 100 000 hours of operation
- ▶ True 360° light output with Tri-Sides LED design.
- ▶ Non-volatile memory recalls last flash pattern used at power up
- ▶ Weatherproof and vibration resistant design for internal or external use
- ▶ Black, white and chrome bezels are available to match the vehicle color
- ▶ Reverse polarity protection
- ▶ Multiple units can be synchronized
- ▶ Color available: 



## ELECTRICAL SPECIFICATIONS

<b>Operating Voltage:</b>	12 to 24Vdc
<b>Maximum Current:</b>	2.5A at 12Vdc / 1.25 at 24Vdc
<b>Average Power:</b>	7.8 Watts (varies with flash pattern)
<b>Maximum Power:</b>	15.6 Watts
<b>Fuse Recommended:</b>	2A

## BEZELS AVAILABLE



## DIMENSIONS

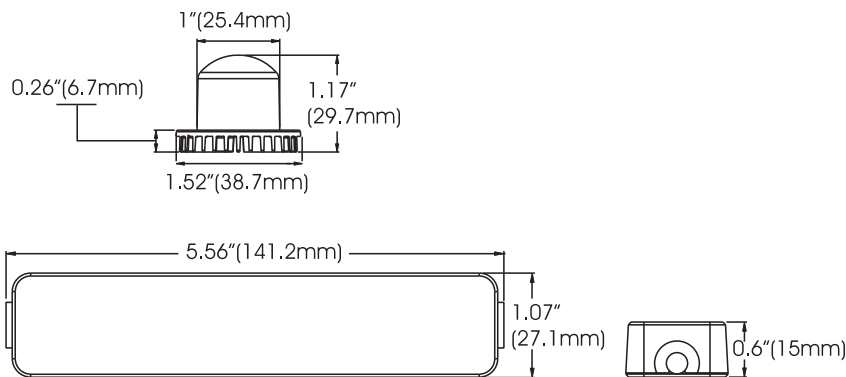

## PRODUCT NUMBERS

Number	Description
10003Z	PROSIGNAL - HAL09 - 9 LED HIDE-A-WAY STROBE - AMBER
10002Z	PROSIGNAL - HAL09 - 9 LED HIDE-A-WAY STROBE - RED
10005Z	PROSIGNAL - HAL09 - 9 LED HIDE-A-WAY STROBE - BLUE
10001Z	PROSIGNAL - HAL09 - 9 LED HIDE-A-WAY STROBE - WHITE
10007Z	PROSIGNAL - HAL09 - 9 LED HIDE-A-WAY STROBE - RED/BLUE
10310Z	PROSIGNAL - HAL09 - SURFACE/MT BEZEL - BLACK
10320Z	PROSIGNAL - HAL09 - SURFACE/MT BEZEL - CHROME
10330Z	PROSIGNAL - HAL09 - SURFACE/MT BEZEL - WHITE