

## SAFETY LIGHTS

# RED ZONE SAFETY LIGHT

**ProSignal™**



## DESCRIPTION

- ▶ The 64812Z™ is a safety light for forklifts. It projects a red line on the ground to designate a perimeter to respect. A light installed on each side of the cage will greatly reduce the risks of foot injury to your employees.
- ▶ The Red Zone safety light is design with a magnifying lens that ensures a clean and visible line on the ground.

## FEATURES

- ▶ Multi-voltage input: 9 to 80Vdc
- ▶ High intensity LED modules (6 LED modules of 3W each.)
- ▶ LEDs rated to 50 000 hours of operation.
- ▶ Cast aluminum housing
- ▶ Heavy duty product, water & Vibration resistant.
- ▶ Weather resistant IP68
- ▶ EMC electromagnetic compatibility

## ELECTRICAL SPECIFICATIONS

Operating Voltage:	9 to 80Vdc
Operating Temperature:	-40°C to 85°C
Maximum Power:	18 Watts

## DIMENSIONS

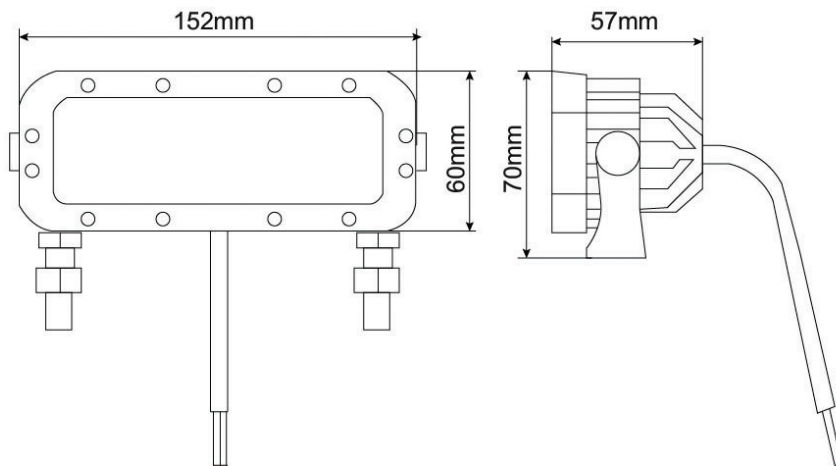

## PRODUCT NUMBERS

Number	Description
64812Z	PROSIGNAL – RED ZONE SAFETY LIGHT FORK LIFT 9-80VDC